

DIL-CUT AÇIK EN KESME ve SIKMA MAKİNESİ

DIL-CUT OPEN WIDTH SLITTING
& SQUEEZING MACHINE

DMS/10



DİLMENLER MAKİNE SANAYİ

Dilmenler, Türkiye, İstanbul'da 1982 yılında kurulan DMS Dilmenler Makine Tekstil San. Tic. A.Ş. 30.000 m² kapalı üretim sahasında 250 kişilik kalifiye ekibi ile Tekstil Boyama ve Terbiye Makineleri alanında üretim yapmaktadır.

Dilmenler has been established in 1982 and continues to manufacture Textile Dyeing and Finishing Machinery with a closed area of 30.000 m² and a qualified staff of 250 people.

SERTİFİKALARIMIZ

ISO 9001: 2008 Kalite Yönetim Sistemi,
EN ISO 3834-2 Metalik malzemelerin ergitme
kaynağı için kalite şartları,
97/23/EC Basınçlı Ekipmanlar Direktifi.

CERTIFICATIONS

ISO 9001: Quality Management System,
EN ISO 3834-2 Quality Conditions for
welding metallic equipments.
97/23/EC Pressure Equipment Directive.





DMS 10 DIL-CUT AÇIK EN FULARLI TÜP KESME MAKİNESİ,

Tüp halindeki kumaşların ıslak ve kuru formda ön sıkılması, kesilerek açık en haline getirilip fularda homojen bir şekilde sıkılması ve istiflenmesi için dizayn edilmiş ara bir makinedir.

MAKİNA ÖZELLİKLERİ

- › 5-100 m/dk Üretim Hızı
- › Kurulu Güç 22 Kw
- › Halat Sıkma (Opsiyonel)
- › Kesme Ünitesi (Opsiyonel)
- › Sıkma Fuları (Opsiyonel)
- › Doğrusal Plaiter (Dok Sarma yada Kollu Sallama)
- › 80-240 cm Kumaş Çalışma Eni
- › Döner Tabla (Opsiyonel)
- › Halat Burgu Açıcı
- › Çıtalı Ortalayıcı
- › Enzim Yıkama Ünitesi (Opsiyonel)

DMS 10 DIL-CUT OPEN WIDTH SLITTING AND SQUEEZING MACHINE

is suitable to open the tubular fabric in wet and dry form. Fabric is centralized, squeezed and plaited in open width form into a trolley before drying and/or stenter process.

MACHINE SPECIFICATIONS

- › 5-100 m/min Production Speed
- › Installation Power 22 Kw
- › Rope Squeezer (Option)
- › Slitting Unit (Option)
- › Foulard (option)
- › Linear Plaiter (Contact Winder or Swing Arm Plaiter)
- › 80-240 cm Fabric Working Width
- › Turn Table (Option)
- › De-Twister
- › Centralizing Unit
- › Enzyme Washing System (Option)

DIL-CUT AÇIK EN KESME ve SIKMA MAKİNESİ
DIL-CUT OPEN WIDTH SLITTING & SQUEEZING MACHINE

DMS 10



DIL-CUT AÇIK EN KESME ve SIKMA MAKİNESİ
DIL-CUT OPEN WIDTH SLITTING & SQUEEZING MACHINE

DMS 10



DIL-CUT AÇIK EN KESME ve SIKMA MAKİNESİ
DIL-CUT OPEN WIDTH SLITTING & SQUEEZING MACHINE

DMS 10

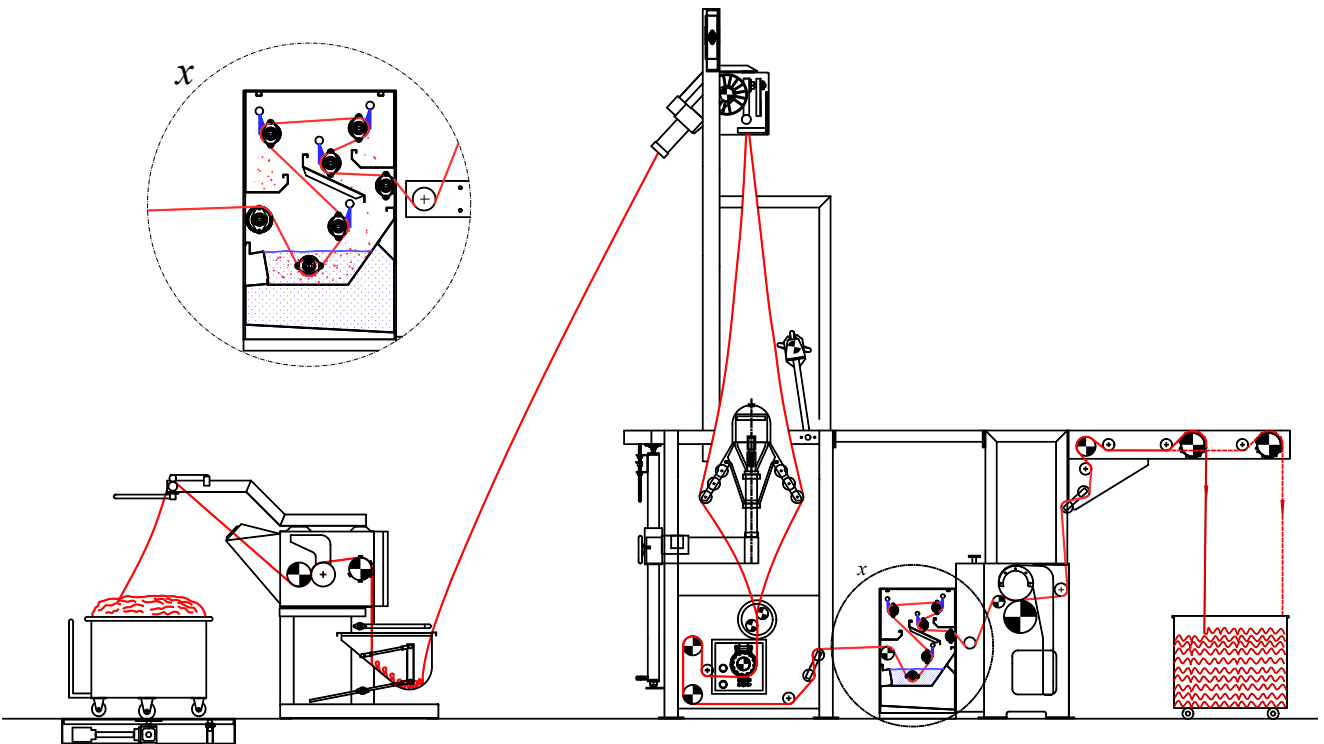



Bodrum

- | | | |
|--------------|--------------|-----------|
| AMERİKA | YUNANİSTAN | BANGLADEŞ |
| EKVATOR | BELARUS | MALEZYA |
| PERU | MISIR | RUSYA |
| ŞİLİ | SURİYE | |
| İNGİLTERE | IRAK | |
| PORTEKİZ | İRAN | |
| FAS | YEMEN | |
| MORİTANYA | TÜRKMENİSTAN | |
| TUNUS | AFGANİSTAN | |
| TANZANYA | PAKİSTAN | |
| GÜNEY AFRİKA | ÖZBEKİSTAN | |
| ALMANYA | HİNDİSTAN | |



İHTİYAÇLARINIZI BİLİYORUZ SİZİN İÇİN ÜRETİYORUZ

DMS DİLMENLER MAKİNE VE TEKSTİL SAN. TİC. A.Ş.

Merkez / Head Quarter

Çobançeşme Mh. Mithatpaşa Cd. Çalışlar Sk. No:5 Kat:5 34196

Bahçelievler / İstanbul / Türkiye

Phone : +90 212 551 18 27

Fax : +90 212 551 11 62

Fabrika / Factory

Ergene 1 OSB Vakıflar Mh. E5 Yolu Üzeri Fabrikalar Sk. No:11 Ergene / Tekirdağ / Türkiye

Phone : +90 282 672 25 07

Fax : +90 282 672 22 63

info@dilmenler.com.tr | www.dilmenler.com.tr

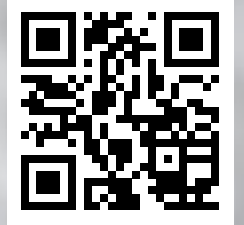

WE KNOW YOUR NEEDS AND PRODUCE FOR YOU